

Intelligent Solutions For Your Success



Choose BATSTAR!

BATSTAR is a German specialist for high performance battery packs and audio solutions for professional mobile radios. With fifteen years of experience in developing and manufacturing professional battery packs, charging devices and audio equipment, we can offer a great range of products in the field of communication.

Clever ideas and quality management are our main focus, to challenge the valuation of suitability. Our ongoing mission is to develop and optimize our products to the best-fit solution that meets the customer's needs. We are always looking for new opportunities to implement your ideas.

We have the ambition to produce, offer and deliver high quality products, just in time with a fair value, to meet the client requirements. Before delivering our products, the goods have to get through a detailed quality control to get the seal of BATSTAR guarantee.

With a first-class service, which is our qualified and motivated sales team, we serve customers all over the world. The BATSTAR-Team knows more than just a part number of the product you are looking for. If you have any specific question or you want to place an order, please contact us for individual expert advice.

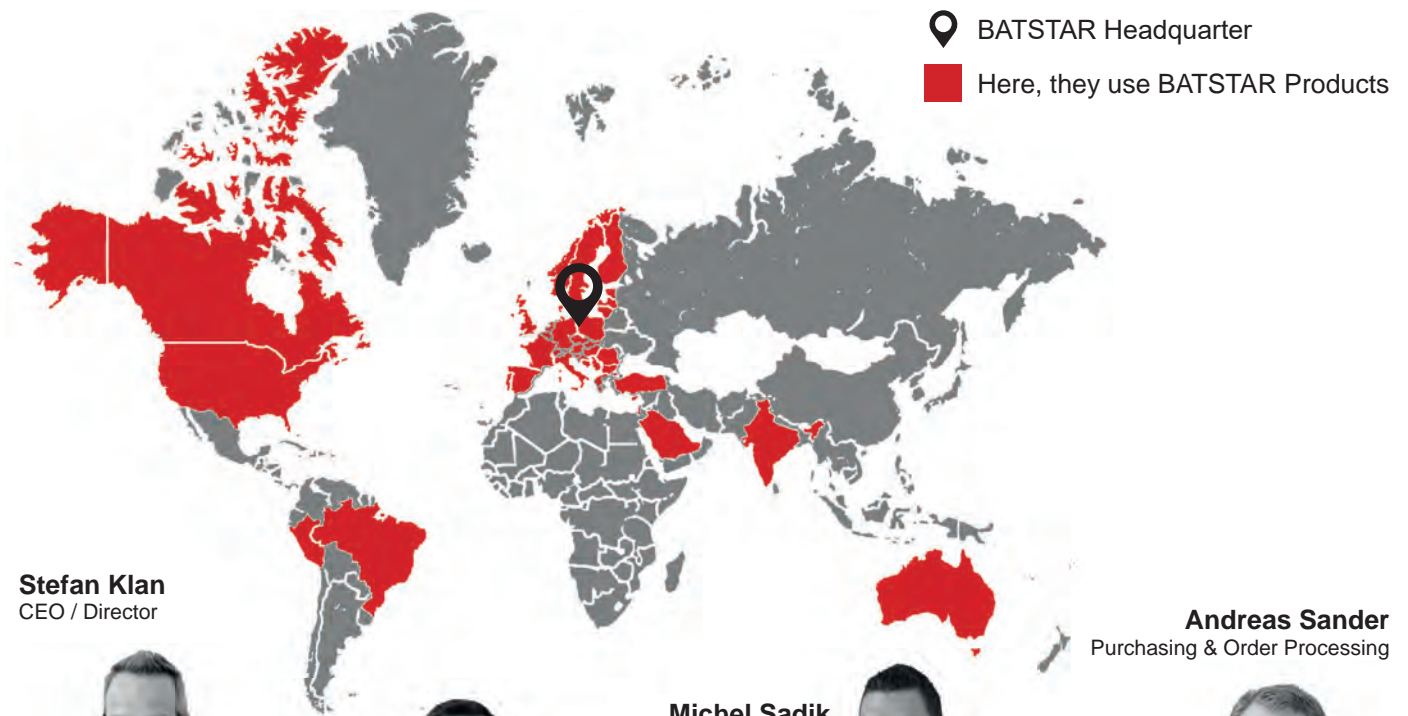

**Stefan Klan**  
CEO / Director



**Andreas Sander**  
Purchasing & Order Processing



**Michel Sadik**  
Head of Sales



**Nassir Jakubi**  
Sales Manager





## New Headset for Offices, Depots & Pick-by-Voice Systems

As a manufacturer of professional audio equipment we always listen carefully to our customer's feedback. That's why we developed in the past months a whole new headset for logistic and office environments.

We present a lightweight over-the-head headset with an easy to bend microphone boom and a total weight of just 50 grams. It has the same characteristics as our BATSTAR Comfort-Headset for the industry - it's build out of high quality materials, it has an excellent noise cancelling microphone and it's easy to assemble and disassemble following the BATSTAR „Easy-Repair“ system.



Part-No.: 5 2430 00 X XXXX



The lightweight Headband can be adjusted in different steps to provide a comfortable use for multiple users. The soft sponge pad makes wearing the headset more comfortable and can be easily replaced anytime.



A water protected noise cancelling microphone provides high quality voice transmission. It is suitable for operating temperatures from - 40 up to +80 °C. The microphone foam can be replaced very easily for hygienic purposes.



Due to the „Easy-Repair“ principle, the headset can be disassembled quickly, so broken parts can individually get exchanged. This system saves money and time and has proven itself in many logistic companies over the years!



The microphone boom allows a 280° rotation for a use on left and or right ears. It can be adjusted with one hand while wearing it. Due to the durable design, it can be used in e.g. in warehouses and industrial businesses.

## Behind-The-Head Headset

- Flat and lightweight design with about 50 g for a high wearing comfort
- IP-safety class IP54
- Adjustable headband in 14 steps for multiple users
- Easy to adjust microphone boom
- Water protected, noise cancelling microphone element, transmitting superior audio quality
- Can be used in frozen storage areas and suitable for use with a helmet

Part-No.: 5 2110 00 X XXXX



## D-Shape Headset

- Lightweight design with only 20 g for a comfortable long time use
- Rubber ear-loop prevents slipping
- Bendable and rotatable gooseneck microphone
- High quality speaker element for excellent sound
- Industrial microphone element for safe and private communication

Part-No.: 5 6200 00 X XXXX



## Comfort Ear-Bud with Ear-Hook Headset

- Bendable rubber ear-hook for a secure and comfortable use
- Comfort ear-bud with replaceable hygienic foam
- Adjustable gooseneck microphone
- Suitable for industrial environments

Part-No.: 5 6171 00 X XXXX





Overhead-Comfort Headset



Part-No.: 5 8121 00 X XXXX / 5 8123 00 X XXXX



The Comfort-Headband is available in 2 sizes - „S“ and „L“. It can be adjusted in 8 steps to provide a comfortable use for all users. The Soft and flexible headband pads can be replaced for hygienic purposes.



A water protected, professional noise cancelling microphone element provides a clear audio and voice quality. It is suitable for frozen storage areas up to -40°C.



The industrial jacketed cable and the internal strengthening at each end provide a safe use and a maximum lifetime in the field.



The microphone boom allows a 280° rotation for both - left and right hander - and can be adjust easily with one hand while wearing it.

Spareparts

part number	description
5 8110 00 9 0001	Screw-Kit for Microphone Boom for Overhead Comfort-Headset
5 8110 00 9 0002	Microphone Boom for Overhead Headset (5 8111 XX X XXXX / 5 8113 XX X XXXX)
5 8120 00 9 0002	Microphone Boom for Overhead Comfort-Headset (5 8121 XX X XXXX / 5 8123 XX X XXXX)
5 8111 00 9 0000	Headband for Overhead Comfort-Headset (Standard Size „S“)
5 8113 00 9 0000	Headband for Overhead Comfort-Headset (Large Size „L“)
5 8110 00 9 1045	Speaker for Overhead Comfort-Headset, with cable to QD-Systemconnector (Quick Disconnect)
5 8110 00 9 1059	Speaker for Overhead Comfort-Headset, with cable to 5-pin Binder-System Adapter
5 8110 00 9 1069	Speaker for Overhead Comfort-Headset, with cable to 6-pin HiRose Adapter
5 8110 00 9 5002	Speaker for Overhead Comfort-Headset, with cable to Vocollect-Talkman®-Systemconnector

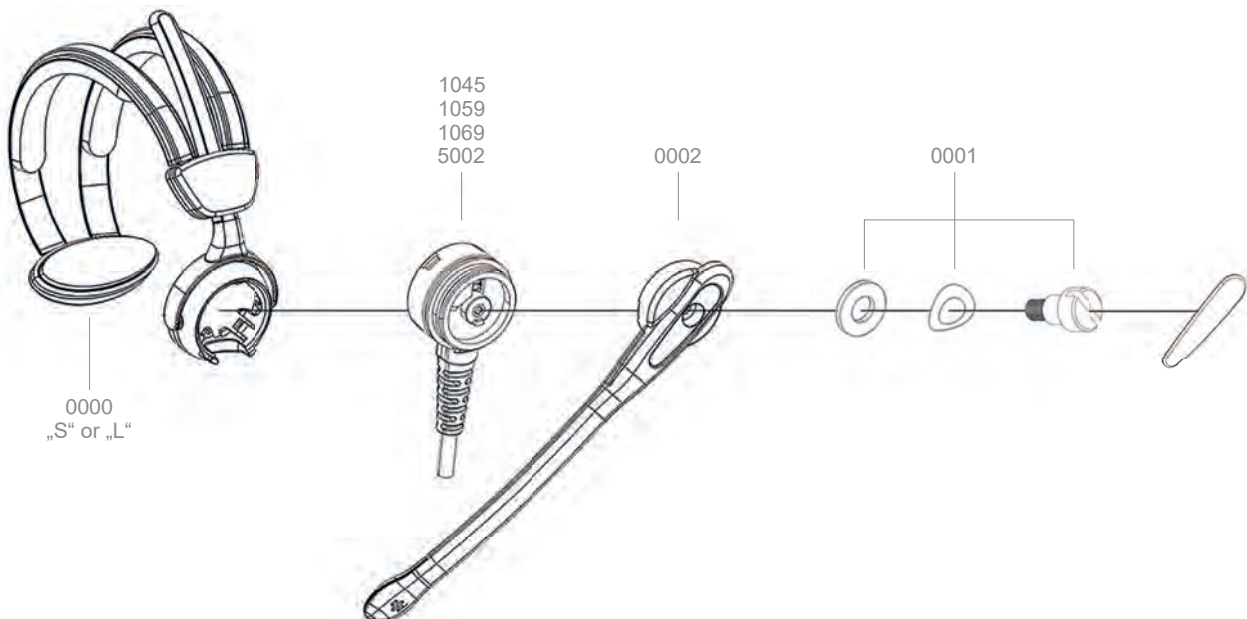

## New Generation of Headsets

We would like to present our new Behind-The-Head Comfort-Headset. A new headset designed for industrial environments and the logistics.

We used carefully chosen electronic parts, as the speaker transmits superior sound and the noise cancelling microphone provides high level speech recognition. There are two types of this headset - a one-side speaker version as usual and additionally a second-speaker version!

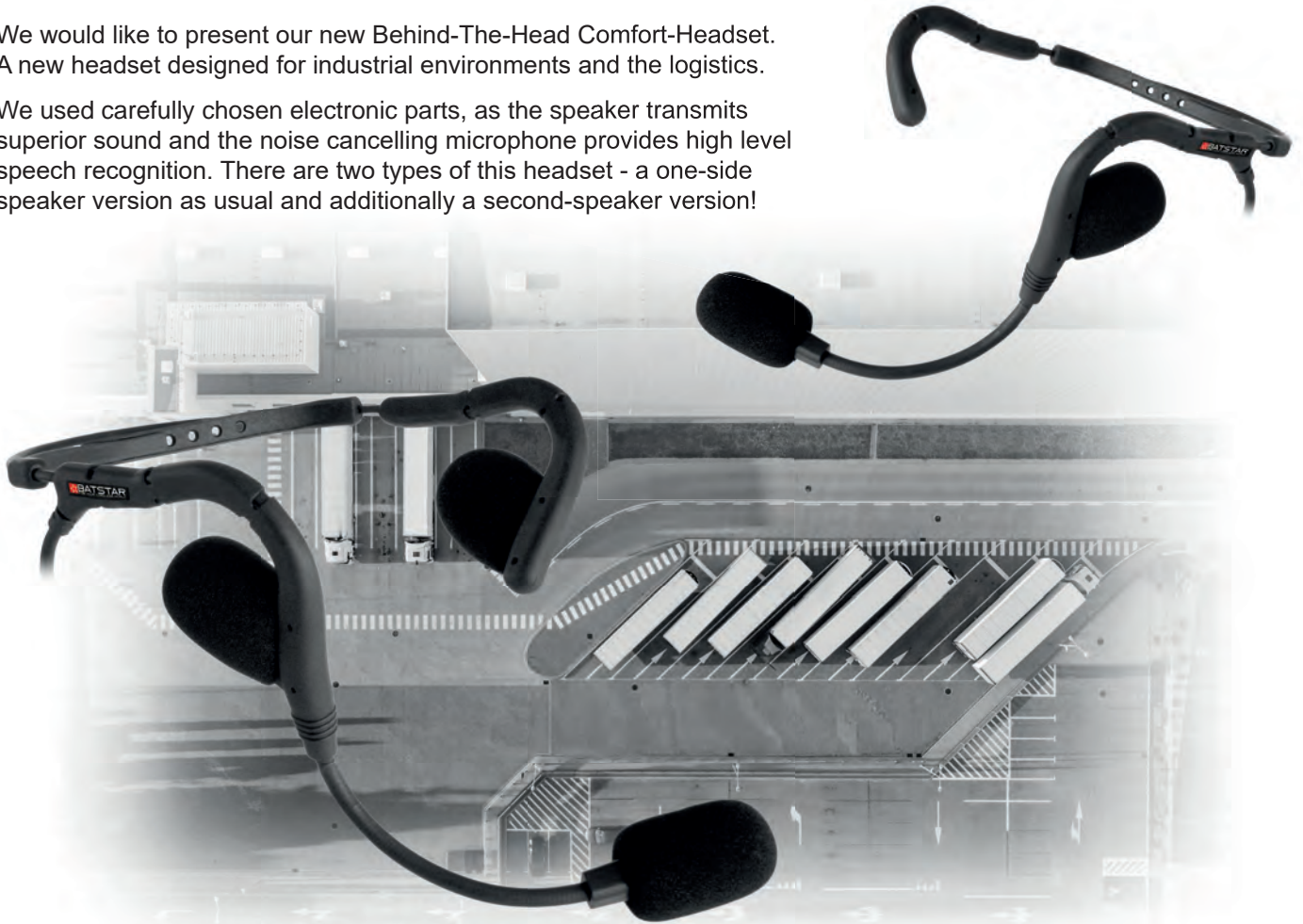

Part-No.: 5 2310 00 X XXXX / 5 2320 00 X XXXX



The Headband can be adjusted in different steps to provide a secure fit for multiple head forms.



The microphone boom can be easily adjusted in front of the mouth for excellent voice transmission. It also is suitable for frozen storage areas up to temperatures of -40 °C.



Because of its robust and durable design, the headset is suitable for rough environments like logistics and industrial environments.



The one-side speaker version is perfect for warehouses with pick-by-voice systems and one-ear-free policies.

Ask our sales team for samples and try it yourself!



Flexible. Reliable. Clever. BATSTAR.

For companies, who use Voice-Picking Systems, we developed a light-weight and ergonomic headset. Due to its modular design, combined with the BATSTAR „Easy-Repair“-System you can easily replace broken spareparts and hygienic parts.

All in all, it's cost-efficient and provides high quality voice- and audio transmission. For a safe and comfortable use, you can bend the ear-hooks around your ear to stabilize the headset.



Part-No.: 5 2420 00 X XXXX



Adjustable ear-piece, made out of soft and flexible material suits users from small to large size ears, due to its C-shaped form. The large ear-pad provides even more comfort to the ears.



The water protected microphone element with professional noise cancelling function, is suitable for an operating temperature of -40 °C to +80 °C and provides superior sound for an excellent communication.



An adjustable and flexible mic boom allows a 280° rotation for the use on the right or left ear, always keeping the user's most comfortable position.



The C-Shape Headset is exclusive designed for an easy handling in industrial environments. Due to the BATSTAR „Easy Repair“-System broken parts can easily and fast be replaced.



## BATSTAR Earmuff Collection

All types of BATSTAR Dual Earmuff Headsets are easy to use due to the big control panel and the adjustable microphone boom. A wide range of different functions are possible, so you can choose the perfect headset for your individual business.

With an IP safety class of IP56, the Earmuffs are suitable for any environment. The Dual Earmuff Behind-The-Head Headset is especially designed for the use with a helmet.

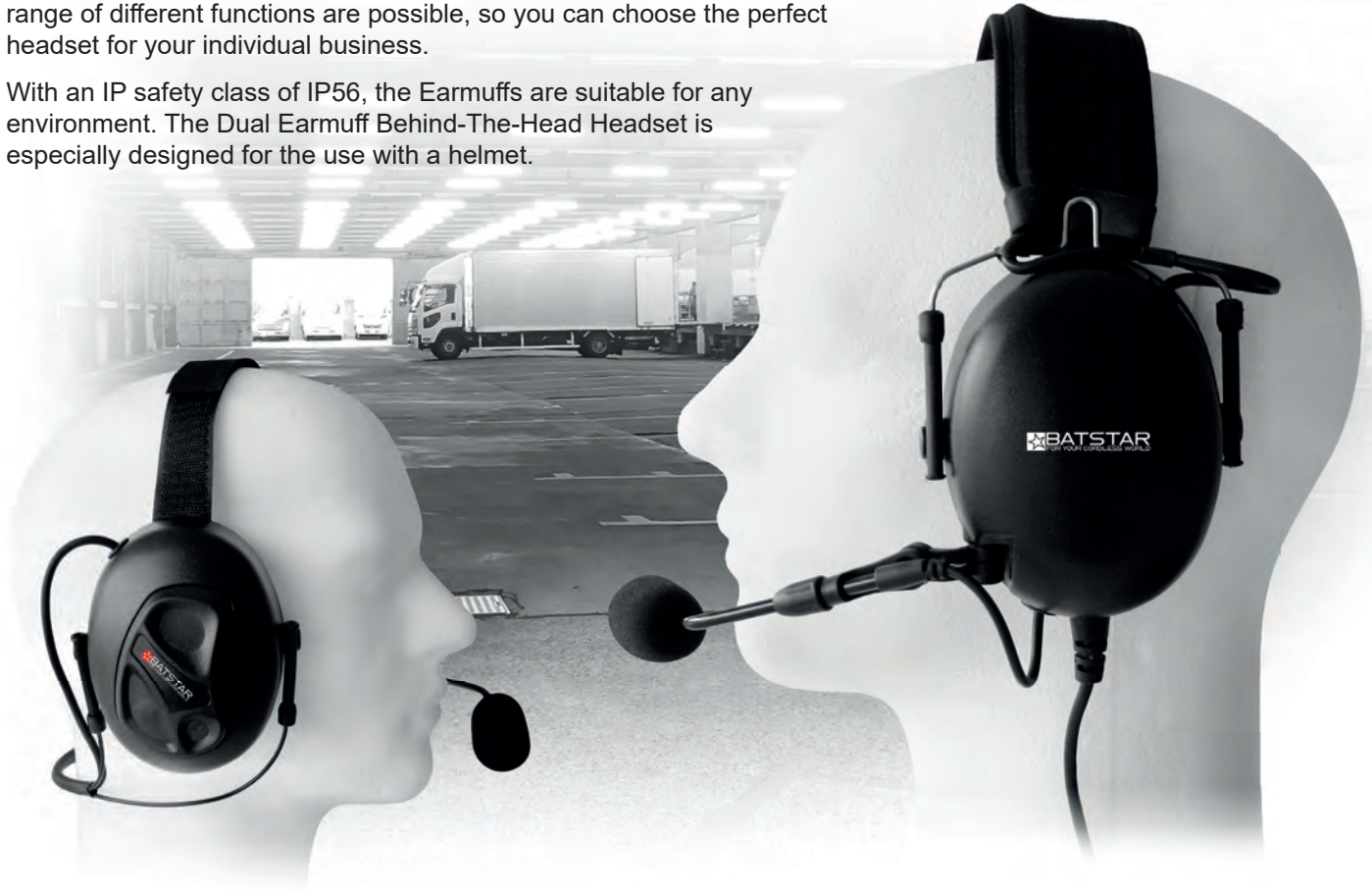

Part-No.: 5 8810 00 X XXXX / 5 8910 00 X XXXX



Digital Noise Cancelling or just a noise cancelling Microphone? PTT or no PTT? Volume Control and an Emergency button? Or would you like to get a programmable button instead? Choose the features you need for your business!



The microphone boom can be easily adjusted in front of the mouth for excellent voice transmission. It also can be replaced as a sparepart, so you can repair it anytime. It is suitable for frozen storage areas up to temperatures of -40 °C.



The Dual Earmuff Behind-The-Head Headset is especially designed for the use with a helmet.



All types of BATSTAR Dual Earmuff Headsets are easy to use due to the big control panel and the adjustable microphone boom. (IP56)



## Spareparts and Accessories for BATSTAR CLASSICS - Headset Collection

part number	description	
5 2110 00 9	0001	Temple Pad (fixing pad) for Behind-The-Head Headset packing unit: 10 pieces overpacking unit: 100 pieces
5 2110 00 9	0002	Ear Pad (side of speaker) for Behind-The-Head Headset packing unit: 10 pieces overpacking unit: 100 pieces
5 5120 00 9	0000	Ear Foam Pad for Comfort Earbud with Ear-Hook packing unit: 10 pieces overpacking unit: 100 pieces
5 6200 00 9	7103	Clip for Audiocable (Ø = 2 mm) for D-Shape Headset packing unit: 10 pieces overpacking unit: 100 pieces
5 8110 00 9	7101	Acoustics Microphone Foam Shield Waterproofed (Silicon-Teflon treated) for Overhead Comfort-Headset & Behind-The-Head Headset packing unit: 25 pieces overpacking unit: 250 pieces
5 8110 00 9	7102	Acoustics Microphone Foam Shield (Standard) for Overhead Comfort-Headset & Behind-The-Head Headset packing unit: 25 pieces overpacking unit: 250 pieces
5 8110 00 9	7103	Clip for Audiocable for Overhead Comfort-Headset & Behind-The-Head Headset packing unit: 10 pieces overpacking unit: 100 pieces
5 8110 00 9	7106	Oval Foam Temple Pad (fixing pad) for Overhead Comfort-Headset packing unit: 10 pieces overpacking unit: 100 pieces
5 8110 00 9	7107	Ear Pad (side of speaker) for Overhead Comfort-Headset packing unit: 25 pieces overpacking unit: 125 pieces
5 8110 00 9	7108	Mounting Disk for for Overhead Comfort-Headset packing unit: 10 pieces overpacking unit: 100 pieces
5 8110 00 9	7109	Headband Pad for Overhead Comfort-Headset packing unit: 10 pieces overpacking unit: 100 pieces



Don't Throw Away Your Favorite Headset!

Buy the headset you like and combine it with an adaptercable to use it with your data terminal. Changing the system? Keep your headsets and just exchange the adaptercables! **So sustainable!**



**Overhead Comfort-Headset**  
HiRose: 5 812X 00 1 1061  
QD: 5 812X 00 2 1045

**Dual Behind-The-Head Headset**  
HiRose: 5 2320 00 1 1061  
QD: 5 2320 00 2 1045

**Behind-The-Head Headset**  
HiRose: 5 2110 00 1 1061  
QD: 5 2110 00 2 1045

**Overhead Lightweight-Headset**  
HiRose: 5 2436 00 1 1061  
QD: 5 2430 00 2 1045





## Adaptercables for Pick-by-Voice Systems & Accessories

part number	connector 1	to connector 2	cable
5 1045 00 4 0140		to Motorola WT40XX / WT41XX	30 cm coiled
5 1045 00 4 1031		to 5-pin Binder-Systemconnector for proLogistik pL-Voice	10 cm straight
5 1045 00 4 1045		to QD-Systemconnector (Quick Disconnect)	30 cm coiled
5 1045 00 4 1091	QD-Systemconnector (Quick Disconnect)	to 9-pin ODU for Toppystem Voxter®	30 cm coiled
5 1045 00 4 2532		to 2.5 mm right angle High Quality Audio Connector 3-pole	30 cm coiled
5 1045 00 4 3532		to 3.5 mm right angle High Quality Audio Connector 3-pole	30 cm coiled
5 1045 00 4 4101		to 3.5 mm right angle Premium Audio Connector 4-pole	15 cm straight
5 1045 00 4 5002		to Vocollect-Talkman®-Systemconnector for Honeywell (Vocollect) Talkman® T5 / A500 / A700	30 cm coiled
5 1059 00 4 1091	5-pin Binder-System Jack	to 9-pin ODU for Toppystem Voxter®	30 cm coiled
5 1069 00 4 1091		to 9-pin ODU for Toppystem Voxter®	30 cm coiled
5 1069 00 4 3541	6-pin HiRose-System Jack	to 3.5 mm straight Premium Audio Connector 4-pole	30 cm coiled
5 1069 00 4 5002		to Vocollect-Talkman®-Systemconnector for Honeywell (Vocollect) Talkman® T5 / A500 / A700	30 cm coiled
5 1069 00 4 5003		to Vocollect-Talkman®-Systemconnector incl. „Operator ID Recognition“ for Honeywell (Vocollect) Talkman® T5 / A500 / A700	30 cm coiled
5 3529 00 4 1045	Standard Audio Jack (3.5 mm / 2-pole)	to QD-Systemconnector (Quick Disconnect)	15 cm straight
5 3549 00 4 1045	Premium Audio Jack (3.5 mm / 4-pole)	to QD-Systemconnector (Quick Disconnect)	12 cm straight
6 6103 00 4 5008	Standard Audio Connector (right angle / 3.5 mm / 2-pole)	to Vocollect-Talkman® Audio Systemconnector (Red Slot)	30 cm coiled
6 7045 00 4 5009	RJ45 Connector	to Vocollect-Talkman® Data Transfer Systemconnector (Blue Slot)	24 cm coiled



---

### Belt-Clip

---

part number		description
6 2801 01 0	5005	Belt-Clip for Vocollect T2 / T2x and A500 / T5

---



### Holster

---

part number		description
6 3900 14 2	0000	Universal Protective-Bag for Intermec, Motorola, Psion and others

---



### Nylon Belt

---

part number		size	length
6 2800 14 3	0000	M	76 cm - 104 cm / 30" - 41" inch
6 2800 14 4	0000	L	89 cm - 116 cm / 35" - 46" inch
6 2800 14 5	0000	XL	104 cm - 132 cm / 41" - 52" inch
6 2800 14 6	0000	XXL	119 cm - 147 cm / 47" - 58" inch
6 2800 14 7	0000	XXXL	134 cm - 162 cm / 53" - 64" inch

---



### Voice Training Equipment for Professional In-House Training, Instruction of Employees and More

---





part number		description
6 6101 00 4	5008	Wired Listening Kit for Vocollect TR-601-1: Set of Audio Adapter / Adaptercable with 3.5mm right angle Standard Audio Connector (AUX) and Mobile Travel / Demonstration Speaker
6 6103 00 0	0001	Mobile Travel / Demonstration Speaker with Bluetooth, 3.5 mm AUX Socket and Micro USB Port for Charging the Built-in Li-ion Battery inclusive Fastening Strap
6 6103 00 4	5008	Audio Adapter / Adaptercable: Vocollect-Talkman®-Systemconnector (Red) to 3.5 mm right angle Standard Audio Connector (AUX) - replaces Vocollect TR-601-103

---



## Connectors for Pick-by-Voice Systems



### BATSTAR High Quality Audio Connectors

	part number	description
	2531	to 2.5 mm straight High Quality Audio Connector 3-pole
	2532	to 2.5 mm right angle High Quality Audio Connector 3-pole
	3531	to 3.5 mm straight High Quality Audio Connector 3-pole
	3532	to 3.5 mm right angle High Quality Audio Connector 3-pole



### BATSTAR Connector for Jabra

	part number	description
	1045	QD-Systemconnector (Quick Disconnect)

### Connector for BATSTAR Audio Solutions



	part number	description
	1061	6-pin HiRose-Systemconnector
	1069	6-pin HiRose-System Jack

### Connector for Topsystem Voxter®



	part number	description
	1051	5-pin Binder-Systemconnector
	1059	5-pin Binder-System Jack
	1091	9-pin ODU Connector



Connector for proLogistik pL-Voice

	part number	description
	1031	5-pin Binder-Systemconnector
	1039	5-pin Binder-System Jack





Connector for Phonak Headset Series 620

	part number	description
	1041	5-pin Binder-Systemconnector
	1049	5-pin Binder-System Jack

Connector for Motorola

	part number	description
	0140	Connector for WT40XX / WT41XX

Connector for Vocollect-Talkman®

	part number	for device
	5002	Vocollect-Talkman®-Systemconnector (Yellow Slot)
	5003	Vocollect-Talkman®-Systemconnector inclusive "Operator ID Recognition" (Yellow Slot)
	5008	Vocollect-Talkman® Audio Systemconnector (Red Slot)
	5009	Vocollect-Talkman® Data Transfer Systemconnector (Blue Slot)



BATSTAR GmbH  
Ungerather Str. 87  
D-41366 Schwalmtal

Telefon: +49(0)2163/57556-0  
Telefax: +49(0)2163/57556-50

E-Mail: [info@batstar.de](mailto:info@batstar.de)  
Web: [www.batstar.de](http://www.batstar.de)  
Shop: [www.batstar24.de](http://www.batstar24.de)



Unless it is not clearly identified as an original, the listed articles relate to alternative products of BATSTAR and not to the original product. Brand and company names are partially registered trademarks of the respective owner and serve merely for indicating the compatibility. Pictures may vary from the original product. Errors, omissions and price alterations are excepted. Our general terms and conditions apply.